



Whole Blood Column Kit

Order no. 130-093-545

Contents

1. Description
 - 1.1 Background information
 - 1.2 Technical specifications
 - 1.3 Applications
 - 1.4 Reagent and instrument requirements
2. Use of Whole Blood Column Kit
 - 2.1 Reagent and column preparation
 - 2.2 Magnetic separation using Whole Blood Columns

1. Description

Components	10 Whole Blood Columns columns and plungers, sterile packed. 50 mL Whole Blood Column Elution Buffer contains stabilizer and 0.09% sodium azide.
Storage	Store Whole Blood Columns dry and protected from light at room temperature. Store Whole Blood Column Elution Buffer at 2–8 °C. The expiration date is indicated on the box label. Do not use after this date.

1.1 Background information

The patented MACS® Column Technology is based on the use of MACS MicroBeads, MACS Columns and MACS Separators. Whole Blood Columns have been developed for the gentle isolation of cells labeled with MACS Whole Blood MicroBeads. As MACS MicroBeads are extremely small, superparamagnetic particles, a high-gradient magnetic field is required to retain the labeled cells. Whole Blood Columns contain an optimized matrix to generate this strong magnetic field when placed in a permanent magnet such as the MidiMACS™ Separator, QuadroMACS™ Separator, VarioMACS™ Separator, SuperMACS™ Separator or SuperMACS™ II Separator. Whole Blood Columns contain a hydrophilic coating which allows rapid filling. This coating is washed out by rinsing the Whole Blood Column with buffer before separation. After incubation with MACS Whole Blood MicroBeads, the cell suspension is loaded onto the Whole Blood Column. The unlabeled cells run through while the magnetically labeled cells are retained on the Whole Blood Column. The retained material is washed with buffer to remove unlabeled material. After removal of the Whole Blood Column from the magnetic field, Whole Blood Elution Buffer is applied to the column, and the magnetically retained cells are eluted as the positively selected cell fraction, using the plunger supplied with the Whole Blood Column.

1.2 Technical specifications

- Column capacity: separation of leukocytes from 0.25 mL up to 15 mL human anticoagulated whole blood.
- Columns are “flow stop” and do not run dry.
- Void volume: 600 µL. Reservoir volume: 7.5 mL.
- Typical flow rate for phosphate-buffered saline (PBS) containing 0.5% bovine serum albumin (BSA): 2.7–3.3 mL/min.
- Whole Blood Columns are for single use only.

1.3 Applications

Whole Blood Columns have been developed for positive selection of leukocyte subsets from anticoagulated whole blood labeled with MACS Whole Blood MicroBeads in combination with a MACS Separator.

▲ Do not use Whole Blood Columns in combination with magnetic particles other than MACS Whole Blood MicroBeads. Magnetic forces in the column are very high and may damage biological material if other beads are used.

▲ To remove clumps and to prevent aggregates in the sample, pass cells through 30 µm nylon mesh (Pre-Separation Filters, # 130-041-407) before separation.

1.4 Reagent and instrument requirements

- Separation buffer: Prepare a solution containing phosphate-buffered saline (PBS), pH 7.2, 0.5% bovine serum albumin (BSA), and 2 mM EDTA by diluting MACS BSA Stock Solution (# 130-091-376) 1:20 with autoMACS™ Rinsing Solution (# 130-091-222). Keep buffer cold (2–8 °C). Degas buffer before use, as air bubbles could block the column.
▲ **Note:** The recommended separation buffer is PBS supplemented with EDTA and BSA. The suitability of other buffers has to be tested experimentally.
- MACS Whole Blood MicroBeads for magnetic labeling of cells.
- MidiMACS Separator, QuadroMACS Separator, VarioMACS Separator, SuperMACS Separator or SuperMACS II Separator.
- LS Column Adapter (# 130-090-544) for use with VarioMACS Separator or SuperMACS Separator, or Adapter for MS, LS and LD Columns for use with SuperMACS II Separator.
- MACS Acrylic Tube Rack (# 130-041-406) or MACS 15 mL Tube Rack (# 130-091-052).
- (Optional) Pre-Separation Filters (# 130-041-407) to remove cell clumps.

140-002-545.02

Miltenyi Biotec

www.miltenyibiotec.com



Miltenyi Biotec GmbH
Friedrich-Ebert-Straße 68, 51429 Bergisch Gladbach, Germany
Phone +49 2204 8306-0 Fax +49 2204 85197
macs@miltenyibiotec.de

Miltenyi Biotec Inc.
2303 Lindbergh Street, Auburn, CA 95602, USA
Phone 800 FOR MACS, +1 530 888 8871, Fax +1 530 888 8925
macs@miltenyibiotec.com
page 1/3

2. Use of Whole Blood Column Kit

2.1 Reagent and column preparation

1. Adjust Whole Blood Column Elution Buffer to room temperature.
2. Insert Whole Blood Column with the column wings to the front into an MACS Separator according to A), B), or C).

A) Use with MidiMACS™ or QuadroMACS™ Separator

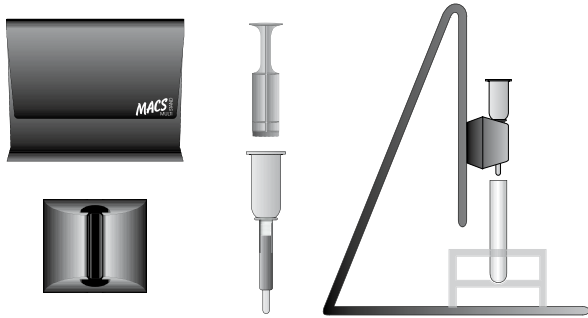

Attach MidiMACS™ Separator or QuadroMACS™ Separator to the MultiStand and place Whole Blood Column in the separator. Place a collection tube under the Whole Blood Column.

▲ **Note:** Check that the ejection blocks in the gap of the magnet are attached before placing the MACS Column into the magnetic field of the MidiMACS or QuadroMACS Separator.

▲ **Note:** Be careful when attaching the QuadroMACS Separator to the MultiStand to avoid trapping your fingers (for details see QuadroMACS Starting Kit data sheet).

B) Use with VarioMACS™ or SuperMACS™ Separator

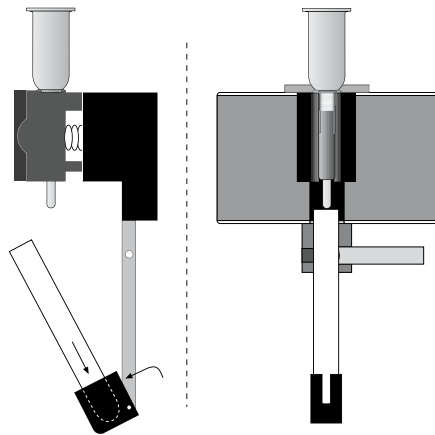

Insert LS Column Adapter in the magnetic field of the VarioMACS™ Separator or the SuperMACS™ Separator (for details, see LS Column Adapter Kit data sheet). Place the Whole Blood Column in the LS Column Adapter and the 13 mL collection tube in the tube holder.

C) Use with SuperMACS™ II Separator

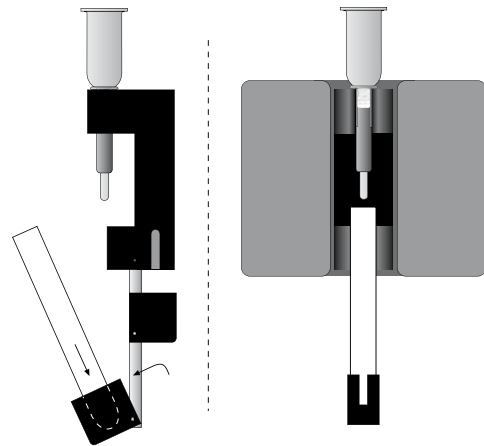

Insert Adapter for MS, LS, and LD Columns in the magnetic field of the SuperMACS™ II Separator (for details, see SuperMACS II data sheets). Place the Whole Blood Column in the Column Adapter and the 13 mL collection tube in the lower tube holder.

3. Prepare Whole Blood Column by rinsing with **separation buffer**: apply 3 mL of **separation buffer** on top of the column and let the buffer run through. Whole Blood Columns are “flow stop” and do not run dry.
4. Discard effluent and change collection tube. The Whole Blood Column is now ready for magnetic separation.

▲ **Note:** Use column immediately after filling to avoid formation of air bubbles caused by warming up. Do not store columns after filling.

▲ **Note:** The time for filling the column with buffer is dependent on the storage conditions, temperature, and humidity. Therefore, the time may vary from a few seconds to several minutes. This filling time has no influence on the quality of the separation.

2.2 Magnetic separation using Whole Blood Columns

▲ For details on magnetic labeling, see MACS Whole Blood MicroBeads data sheets.

▲ Always wait until the column reservoir is empty before proceeding to the next step.

1. Apply magnetically labeled cell suspension onto the prepared Whole Blood Column. Collect flow-through containing unlabeled cells.

▲ **Note:** The reservoir of the Whole Blood Column contains a maximum of 7.5 mL. Samples greater than 7.5 mL should be applied in aliquots to the column.
2. Wash Whole Blood Column with 3×3 mL **separation buffer**. Collect unlabeled cells that pass through and combine with the effluent from step 1.

▲ **Note:** Perform washing steps by adding buffer aliquots only when the column reservoir is empty.
3. Remove Whole Blood Column from the separator and place it on a new collection tube.
4. Pipette 5 mL **Whole Blood Column Elution Buffer** onto the Whole Blood Column. Immediately flush out the magnetically labeled cells by firmly pushing the plunger into the column.

5. (Optional) To increase the purity of the magnetically labeled fraction the eluted fraction can be enriched over a new, freshly prepared MS Column (# 130-042-201, for up to 10^7 magnetically labeled cells) or LS Column (# 130-042-401, for up to 10^8 magnetically labeled cells).

Remaining erythrocytes can be lysed using Red Blood Cell Lysis Solution (10×) (# 130-094-183).

All protocols and data sheets are available at www.miltenyibiotec.com.

Warnings

Reagents contain sodium azide. Under acidic conditions sodium azide yields hydrazoic acid, which is extremely toxic. Azide compounds should be diluted with running water before discarding. These precautions are recommended to avoid deposits in plumbing where explosive conditions may develop.

Warranty

The products sold hereunder are warranted only to be free from defects in workmanship and material at the time of delivery to the customer. Miltenyi Biotec GmbH makes no warranty or representation, either expressed or implied, with respect to the fitness of a product for a particular purpose. There are no warranties, expressed or implied, which extend beyond the technical specifications of the products. Miltenyi Biotec GmbH's liability is limited to either replacement of the products or refund of the purchase price. Miltenyi Biotec GmbH is not liable for any property damage, personal injury or economic loss caused by the product.

MACS is a registered trademark and autoMACS, MidiMACS, MiniMACS, OctoMACS, QuadroMACS, SuperMACS, and VarioMACS are trademarks of Miltenyi Biotec GmbH.

Copyright © 2008 Miltenyi Biotec GmbH. All rights reserved.